

**VERTICAL SECTION
CILL OPTION - A**

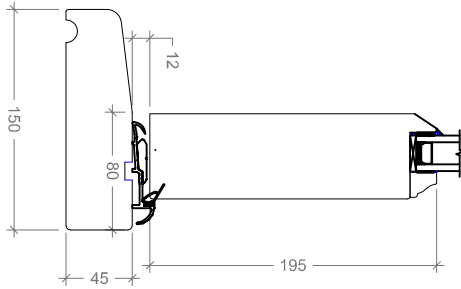

**VERTICAL SECTION
THROUGH FANLIGHT**

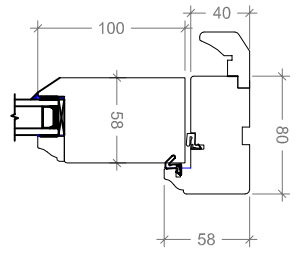
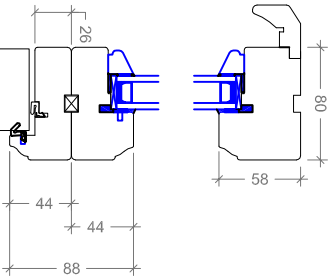

HORIZONTAL SECTION

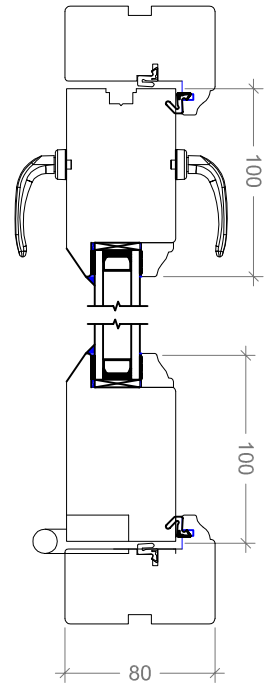

**ASTRAGAL
BAR**

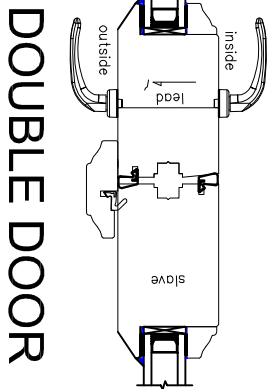
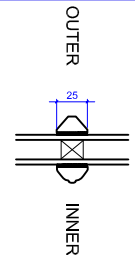

DOUBLE DOOR

CILL OPTION - B

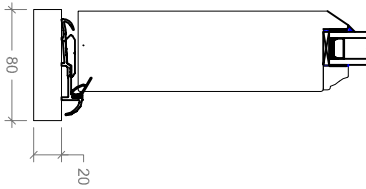

WINGLIGHT CASING SECTION

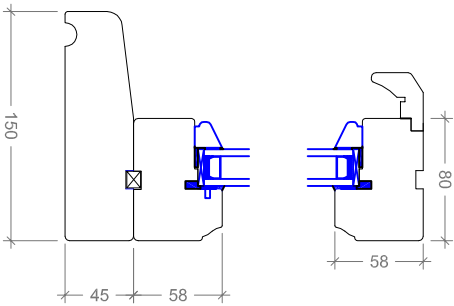
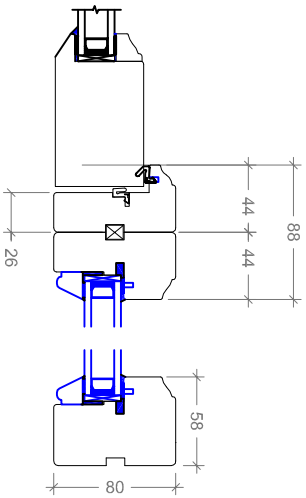

LEFT HAND HUNG

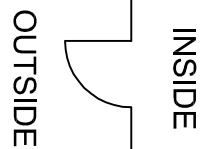

RIGHT HAND HUNG

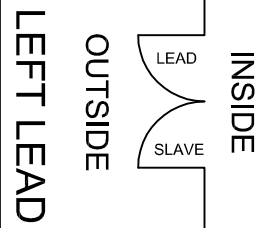
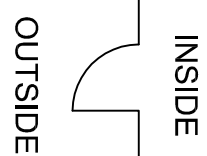

LEFT LEAD

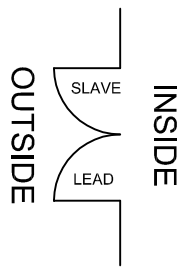

RIGHT LEAD

Drawing number
PJ006-02

Drawn by - date
J Connelly 27/07/2012

Checked by - date

Approved by - date

Scale
Not to scale

Rev no
2